

frostbarber



HITCH

Tie privacy to any workstation.

DESIGN FEATURES

- Designed for a 28" - 30" tall worksurfaces
- Assembles in less than 10 minutes
- Frame made from 75% recycled content
- Aluminum interlocking modular frame
- Cleanable with healthcare-grade cleaners
- Frame and panel can be recycled

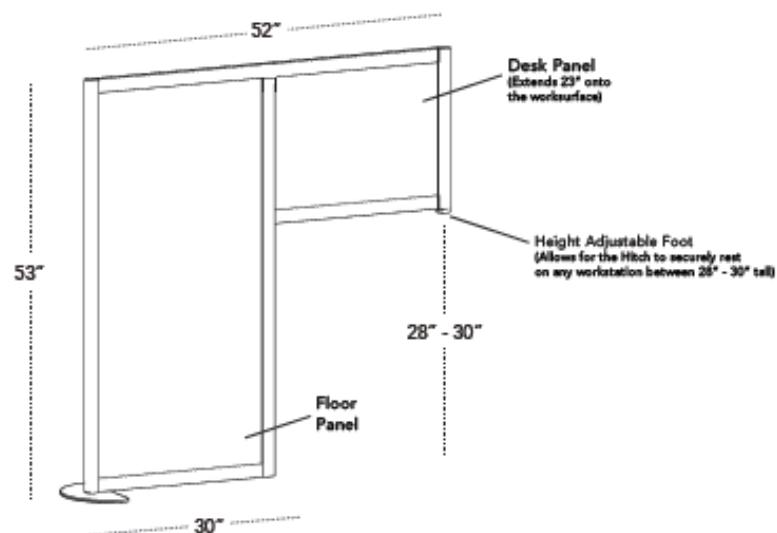

contact Frost-Barber for more information
225-926-5000 info@frost-barber.com

frostbarber



HIDE

A hassle-free escape from the chaos.

STANDARD FINISHES



Charcoal PET



Marble PET

DESIGN FEATURES

- Easily reconfigurable design
- Acoustic material absorbs sound
- PET made from recycled content
- No assembly required
- Capable of storing flat
- Minimal privacy solution



contact Frost-Barber for more information
225-926-5000 info@frost-barber.com